

Technical data sheet

Device support for CEE installation, system length 165 mm,
without CEE

Item number: 7407665



Device support of nominal size 2 for the installation of a CEE plug connection 16 A or 32 A for installation in service outlets and cassettes of nominal size 2, 4, 6 and R7. Device support with protective housing and strain relief. Required minimum installation depth: 190 mm when using a straight connector and 160 mm when an angled connector is used.



St Steel

FS Strip galvanized

Master data

Item number	7407665
Type	GT2CEE
Description 1	Mounting box
Description 2	for CEE16 and CEE32
Manufacturer	OBO
Dimension	175x75x128
Material	Steel
Surface	Strip galvanized
Surface standard	DIN EN 10346
Smallest sales unit	1
Unit of quantity	Piece
Weight	51 kg
Weight unit	kg/100 pc.
CO2 Footprint (GWP) Cradle-to-Gate	2,2204 kg CO2e / 1 Piece

Technical data sheet

Device support for CEE installation, system length 165 mm,
without CEE

Item number: 7407665



Dimensions

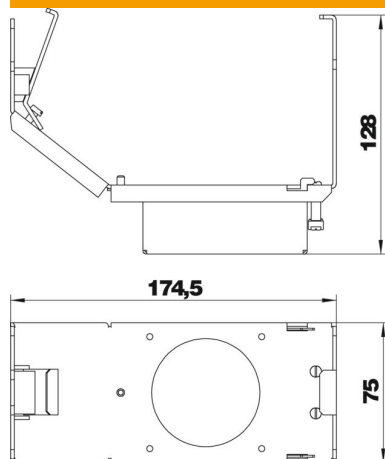

Technical data

Number of installable devices	1
Floor plate	no
Seal installation option	no
Suitable for raised floor installation	yes
Suitable for screed-flush closed underfloor ducts	yes
Suitable for screed-covered underfloor ducts	yes
Suitable for cavity floor installation	yes
Suitable for underfloor ducts	yes